

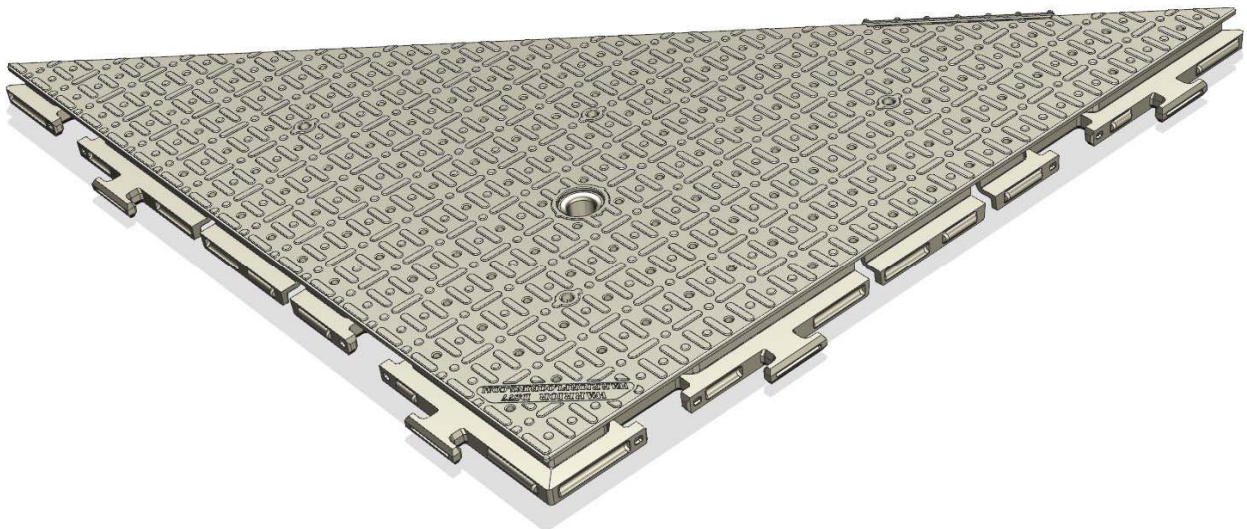

# WARRIOR FLOORING



**INTRODUCING** – The Warrior brand of portable utility flooring for any remote field application. Specially designed for extreme conditions, Warrior floor panels will exceed performance expectations anywhere in the -50°C to +50°C ambient temperature range. Ideal as base camp flooring with special impact resistant modifiers allowing it to perform well across a broad temperature range. Easily connected together in the field to form a large surface area in a matter of minutes.

The Warrior floor panel is designed as a single part number solution for ease of deployment in any location. Delivered as a square panel, individual identical triangular panels can be created utilizing the panel's unique twist lock feature. Once separated, floors can be laid out to accommodate 45° angles for different shelter configurations or for camp pathways.

Among other attributes, the primary value proposition of the Warrior flooring system is the integrated cable management system to allow multiple cable run paths each supporting up to 10 standard CAT 5 or 6 data cables or equivalent. Whether your cable application is data or power, the Warrior flooring system offers your team unprecedented convenience for any field application.

Warrior floor panels are designed to be tough and reliable. The unique "friction hinge" system allows flexibility on uneven surfaces and will accommodate small obstructions underneath the floor surface. Designed with a non-slip surface, and for adequate drainage of surface water, the Warrior temporary flooring system is ideally suited for teams of professionals required to live and work in the field for days, weeks or months at a time. Once your field camp is ready for redeployment, the Warrior flooring system is easily disassembled and cleaned and/or disinfected for repeated use on another mission.

The Warrior Flooring System – expertly designed - field ready.

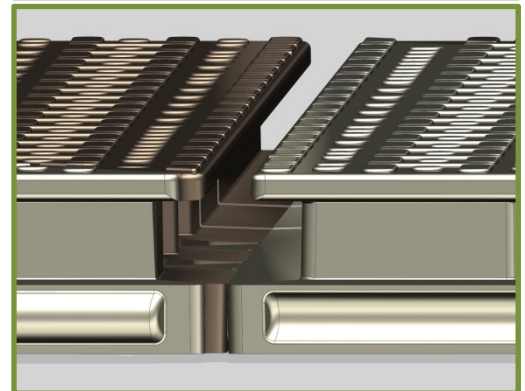
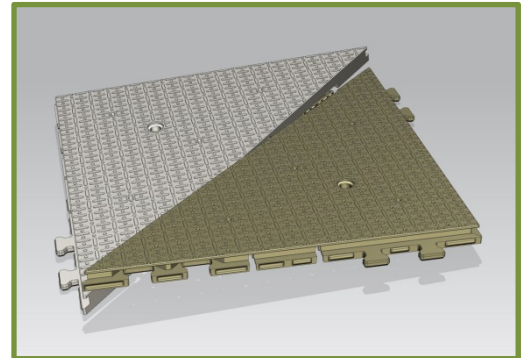

U.S. Patent No. 9,771,725 , U.S. Des. Patent No. D732,208  
CAN Patent No. 2,953,837, Patent Pending (PTC) Worldwide

BESSCO Ventures Inc. P.O. Box 1445 Stn. B., Mississauga, Ontario, CANADA L4Y 4G2  
email: [info@designshelter.com](mailto:info@designshelter.com) Phone: +1-778-558-2172



# WARRIOR FLOORING

Warrior Floor Panels are fabricated utilizing high pressure injection molded polyolefin thermoplastic and delivers the following attributes;

- Single part number design
- Offered at 4 cm (1.5") thick by 77 cm (30.5") square profile. Per panel surface area is 0.3 m<sup>2</sup> (3.23 ft<sup>2</sup>). Optional 1m (39.4") square panels are available
- Integrated cable management system – supports up to 10 x CAT 5 or CAT6 data cables or equivalent
- Optionally offered in either recycled (colored black) or virgin polyolefin thermoplastic (colored desert sand or grey) formulations.
- Superior impact and static load resistance in the -50°C to +50°C ambient temperature range.
- UV protected
- Waterproof
- Non-slip tread surface
- Adequate capacity for a 2 cm (3/4") diameter ground stake
- Environmentally friendly
- Optional anti-static formulation
- Optional non-halogen fire-retardant formulation
- Stackable for stable skid mounted loads.
- Easy to carry including assembly and disassembly in any weather condition. No tools required.
- Unique "friction-hinge" design to accommodate uneven surfaces and small under floor obstructions
- Lightweight at 3.4 kg (8.8 lbs) per panel
- Applicable Industry certifications pending

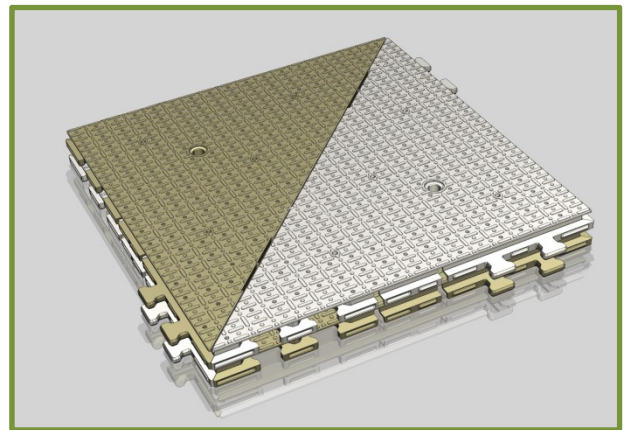
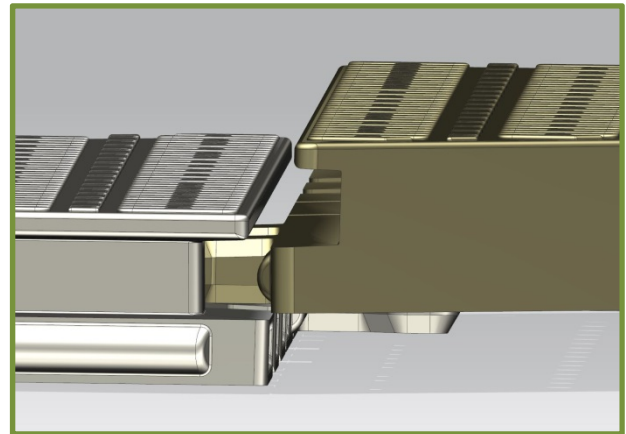
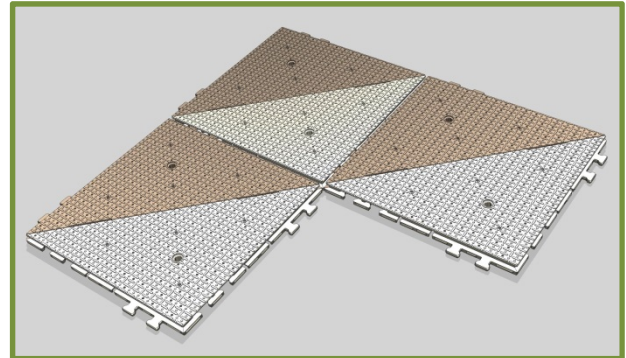

U.S. Patent No. 9,771,725 , U.S. Des. Patent. No. D732,208  
CAN Patent No. 2,953,837, Patent Pending (PTC) Worldwide

WARRIOR Flooring Brochure V7

BESSCO Ventures Inc. P.O. Box 1445 Stn. B., Mississauga, Ontario, CANADA L4Y 4G2  
email [info@designshelter.com](mailto:info@designshelter.com)

Phone: +1-778-558-2172